

**CHAPTER 6.
ELECTRICAL**

SRX600S CIRCUIT DIAGRAM..... 6-1

ELECTRICAL COMPONENTS..... 6-3

IGNITION SYSTEM..... 6-5
CIRCUIT DIAGRAM 6-5
TROUBLESHOOTING 6-7
IGNITION CONTROL CIRCUIT OPERATION 6-12

CHARGING SYSTEM..... 6-13
CIRCUIT DIAGRAM 6-13
TROUBLESHOOTING 6-15

LIGHTING SYSTEM..... 6-17
CIRCUIT DIAGRAM 6-17
TROUBLESHOOTING 6-19

SIGNAL SYSTEM..... 6-23
CIRCUIT DIAGRAM 6-23
TROUBLESHOOTING 6-25
SELF-CANCELLING FALSHER SYSTEM., 6-31
SWITCHES TEST 6-31

ELECTRICAL

SRX600S CIRCUIT DIAGRAM

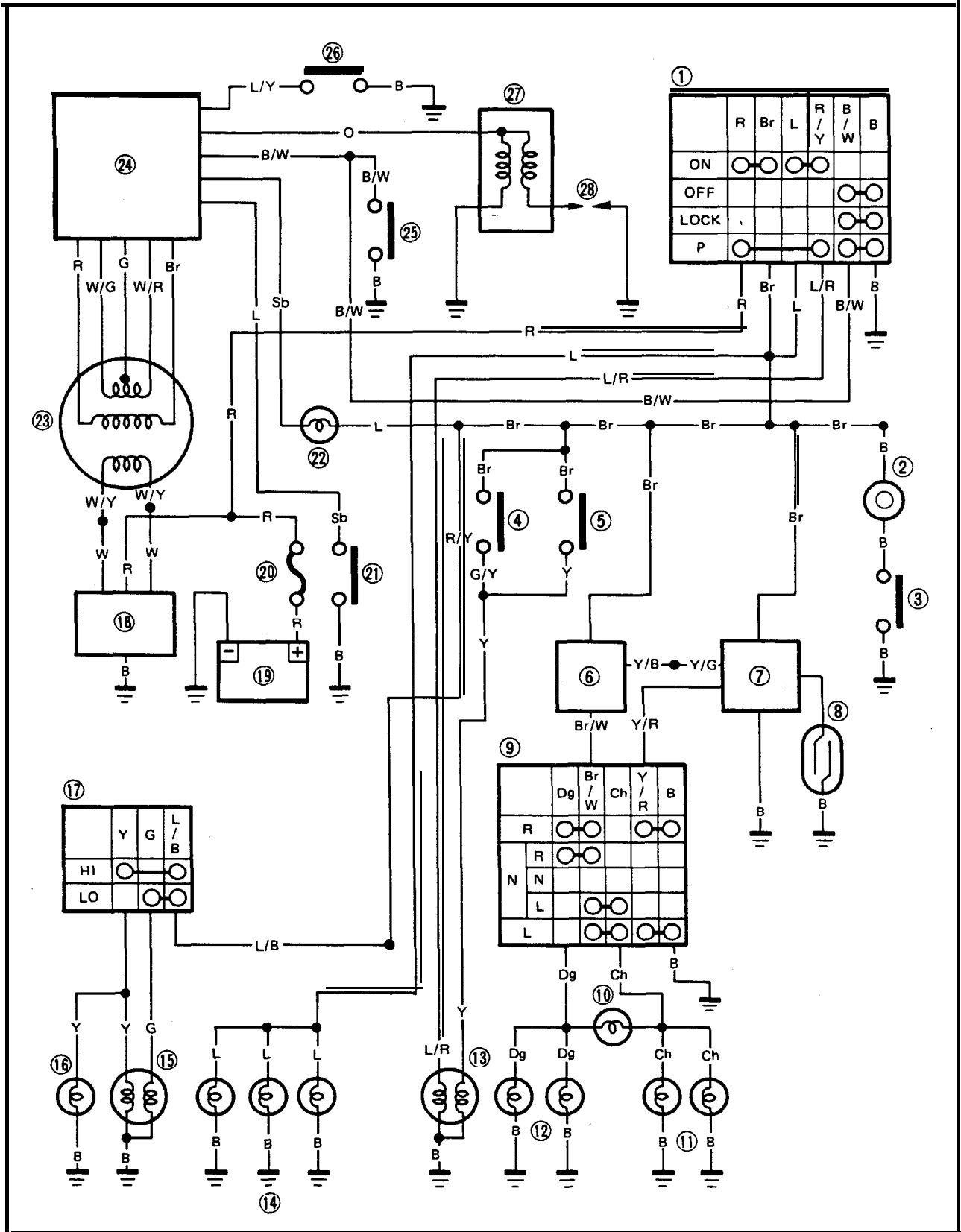

6



- ① Main switch
- ② Horn
- ③ "HORN" switch
- ④ Front brake switch
- ⑤ Rear brake switch
- ⑥ Flasher relay
- ⑦ Cancelling unit
- ⑧ Reed switch
- ⑨ "TURN" switch
- ⑩ "TURN" indicator light
- ⑪ Flasher light (Left)
- ⑫ Flasher light (Right)
- ⑬ Tail/brake light
- ⑭ Meter light
- @Headlight
- @ "HIGH BEAM" indicator light
- @ "LIGHTS" (Dimmer) switch
- ⑮ Rectifier/regulator
- ⑯ Battery
- ⑰ Circuit breaker
- ⑱ Neutral switch
- ⑳ "NEUTRAL" indicator light
- ㉑ CDI magneto
- ㉒ CDI unit
- ㉓ "ENGINE STOP" switch
- ㉔ Sidestand switch
- ㉕ Ignition coil
- ㉖ Spark plug

COLOR CODE

B	Black
R	Red
L	Blue
G	Green
DgDark green
SbSky blue
Br.Brown
OOrange
Y	Yellow
ChChocolate
P	Pink
W	White
-B/WBlack/White
R/YRed/Yellow
L/BBlue/Black
L/RBlue/Red
L/YBlue/Yellow
G/YGreen/Yellow
Br/W.Brown/White
Y/BYellow/Black
Y/RYellow/Red
W/RWhite/Red
W/GWhite/Green
W/YWhite/Yellow



ELECTRICAL COMPONENTS (1)

- ① Wire harness
- ② Rectifier with regulator
- ③ CDI unit
- @Circuit breaker
- ⑤ Battery
- ⑥ Ignition coil
- ⑦ Main switch

SPECIFICATIONS	RESISTANCE
IGNITION COIL:	
PRIMARY	0.48 ~ 0.72Ω
SECONDARY	5.2 ~ 7.8 kΩ
PICKUP	92 ~ 138Ω

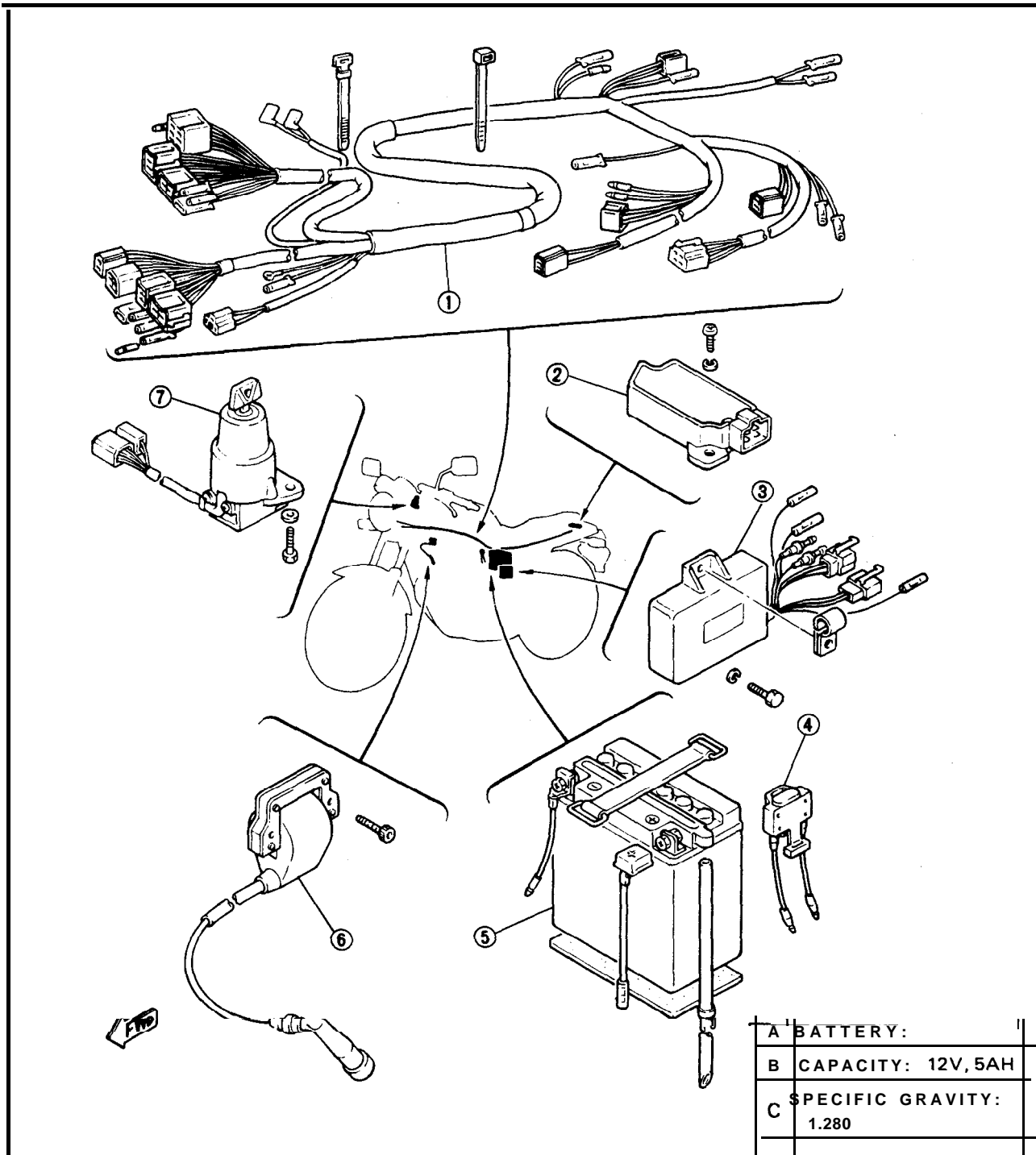

6

ELECTRICAL COMPONENTS (2)

- ① Rear brake switch
- ② Sidestand switch
- ③ Neutral switch
- ④ Flasher relay
- ⑤ Horn

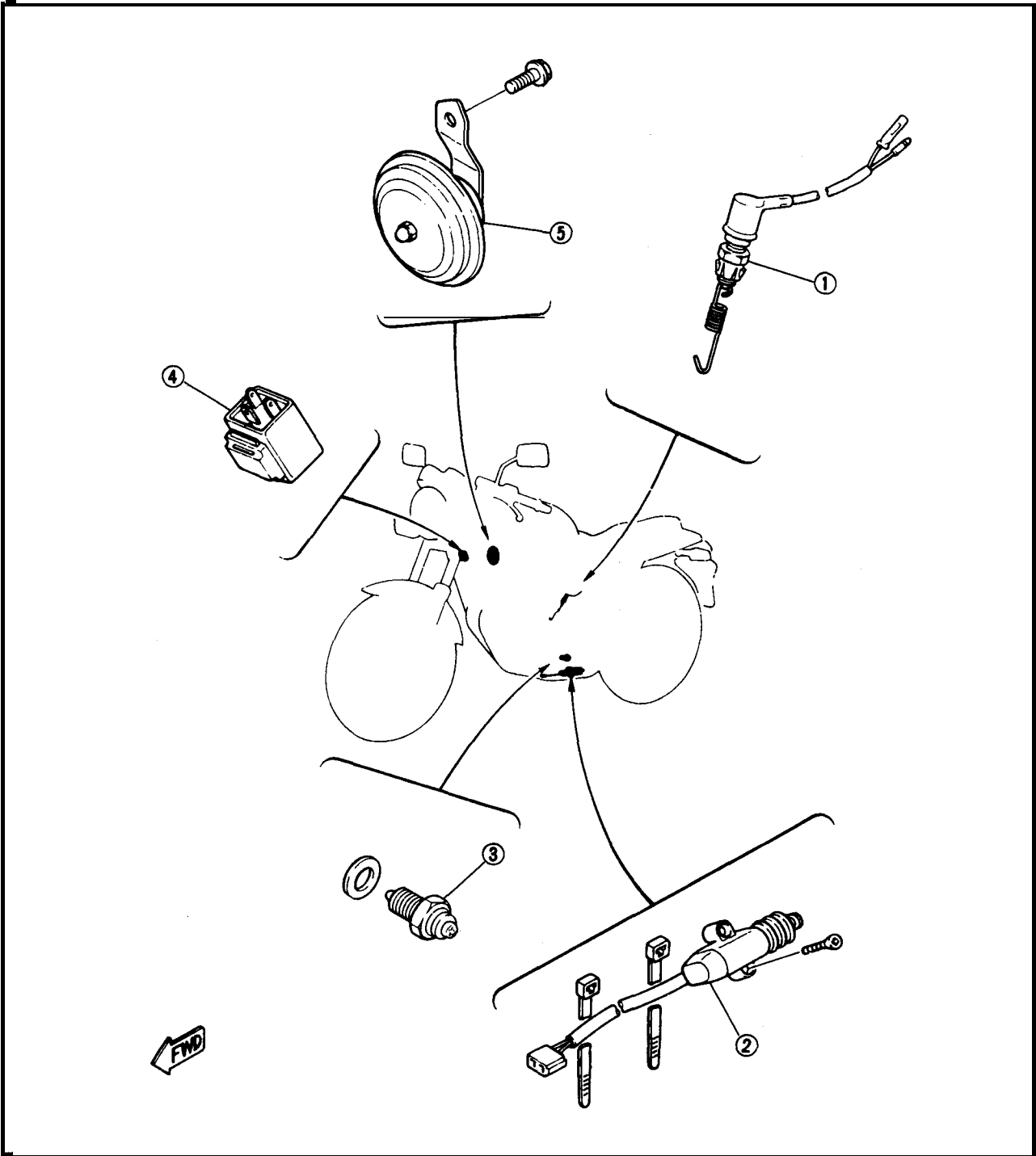

IGNITION SYSTEM

CIRCUIT DIAGRAM

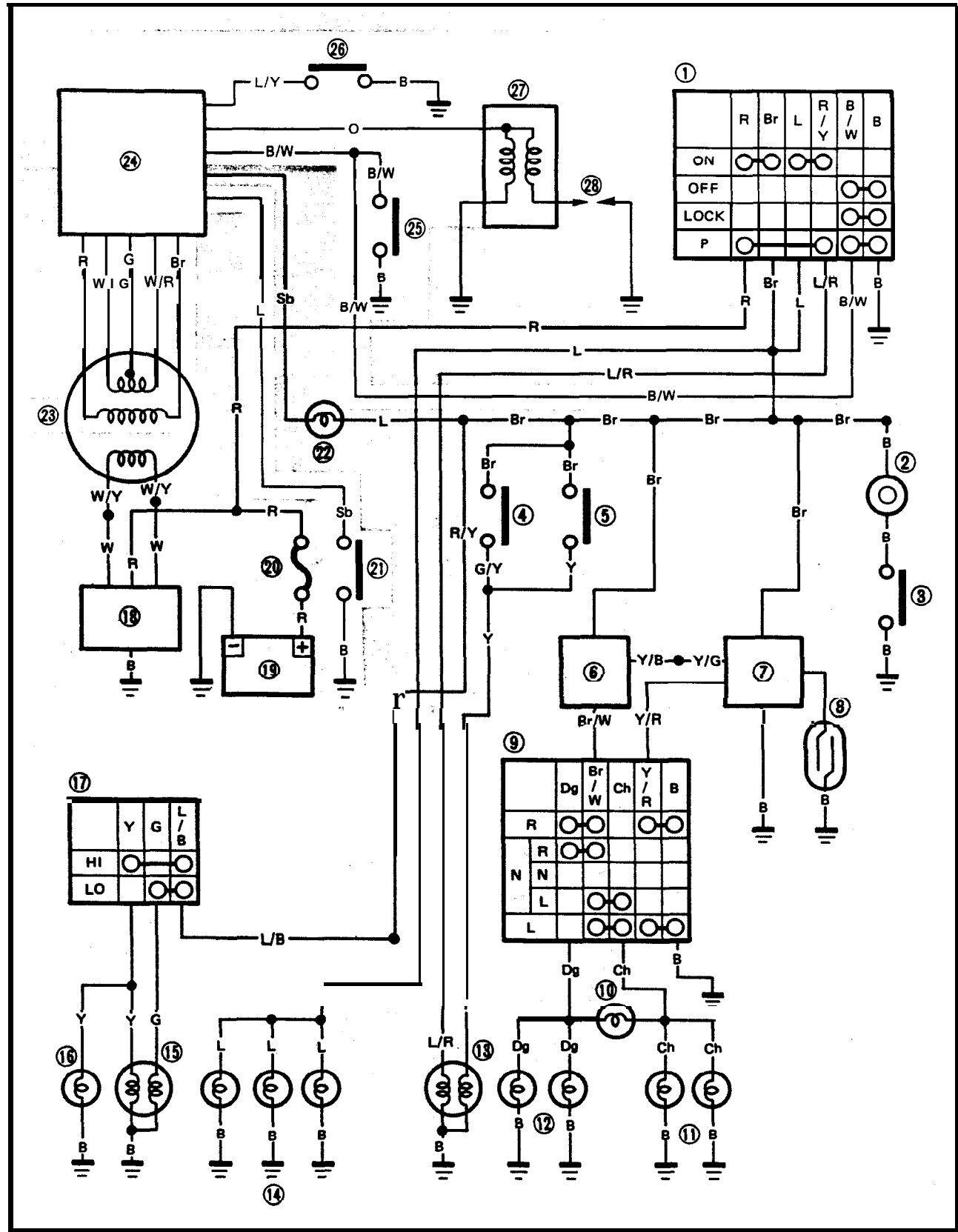

6

Aforementioned circuit diagram shows ignition circuit in wiring diagram.

NOTE:

For the encircled numbers and color codes, see page 6-2.

- ① Main switch
- ②① Neutral switch
- ②③ CD I magneto
- ②④ CDI unit
- @ "ENGINE STOP" switch
- ②⑥ Sidestand switch
- ②⑦ ignition coil
- @ Spark plug

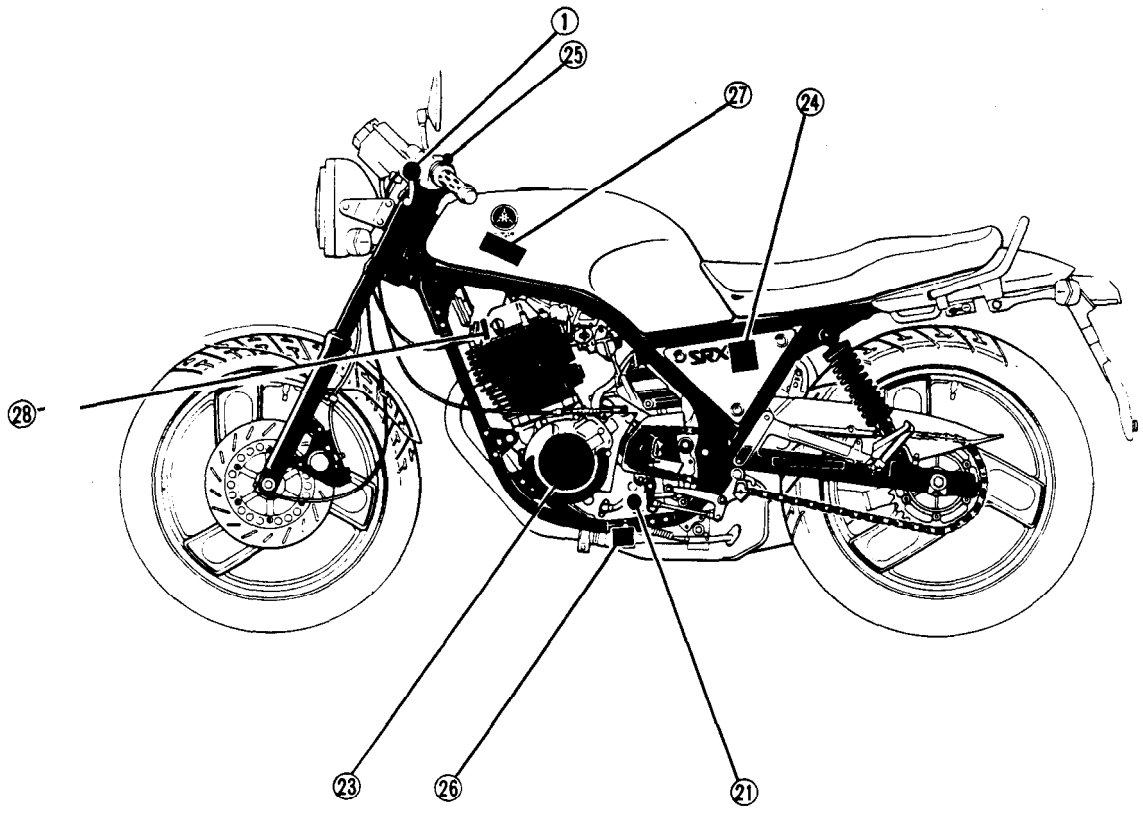

TROUBLESHOOTING

NOTE:

Before this troubleshooting, remove the side covers, seat and fuel tank.

IF IGNITION SYSTEM SHOULD BECOME INOPERATIVE (NO SPARK OR INTERMITTENT SPARK).

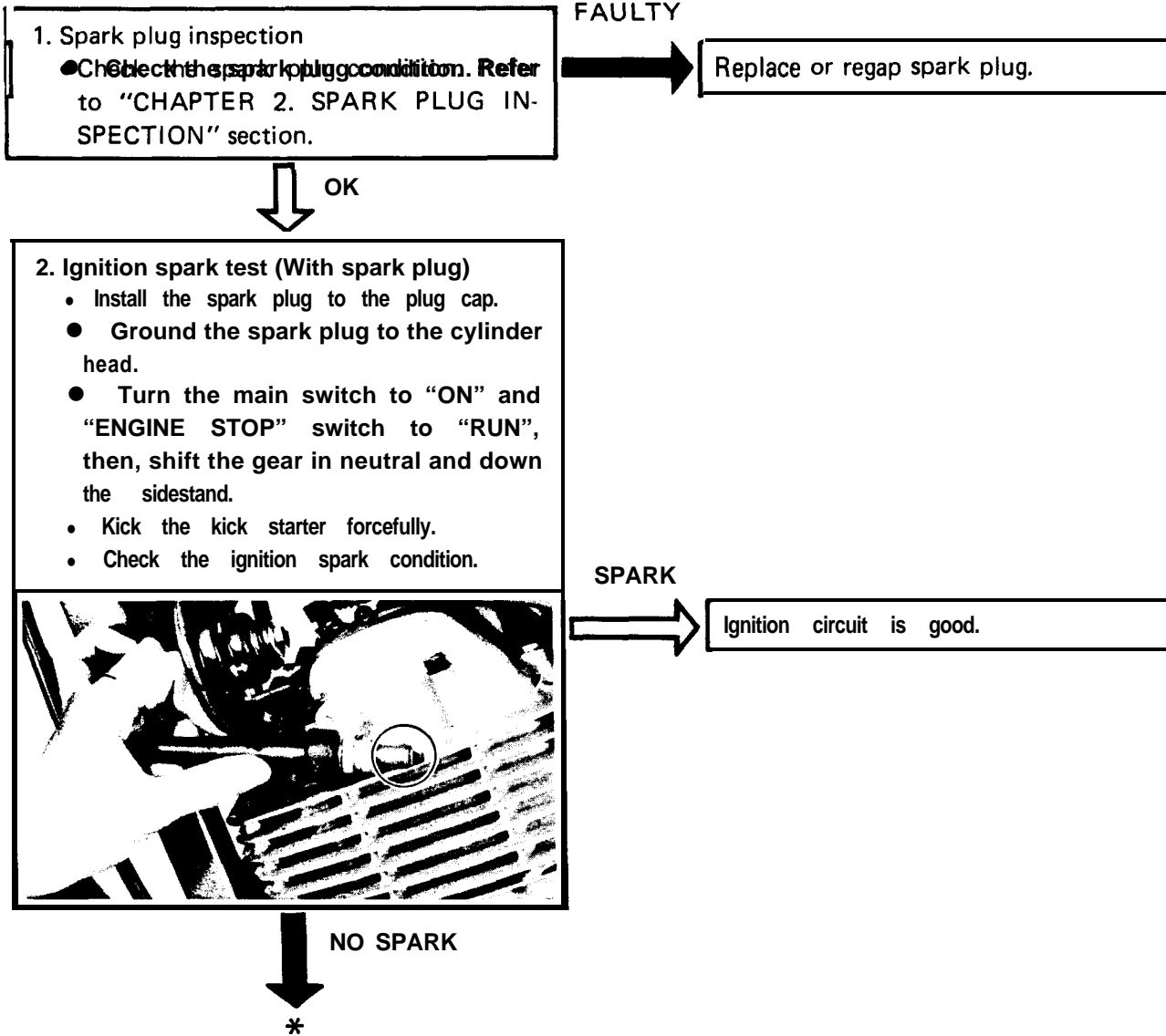

6



3. Ignition spark gap test (Without spark plug and cap)

- Remove the spark plug and plug cap.
- Hold the spark plug lead 6 mm (0.24 in) from the cylinder head.
- Repeat the aforementioned test.
- Check the ignition spark condition.

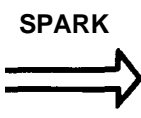

Spark plug and/or plug cap is faulty. Replace faulty part(s).



4. "ENGINE STOP" and main switches conduct check.

- Check the "ENGINE STOP" and main switches for continuity. Refer to "SIGNAL SYSTEM" section.

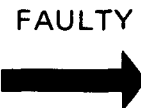

"ENGINE STOP" and/or main switches is faulty. Replace faulty part(s).

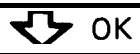

5. Sidestand switch conduct check

- Disconnect the sidestand switch leads (Blue/Yellow ① and Black ②) from the wire harness.
- Connect the Pocket Tester (YU-33260) to the sidestand switch leads.
- Move the sidestand up or down, and check the sidestand switch for continuity.

Sidestand Position	Good Condition	Bad Condition		
		0	x	x
UP ③	0	0	x	x
Down ④	X	0	x	0

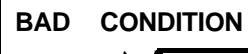

Sidestand switch is faulty. Replace it.

3 : Continuity X : Discontinuity

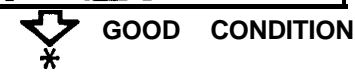
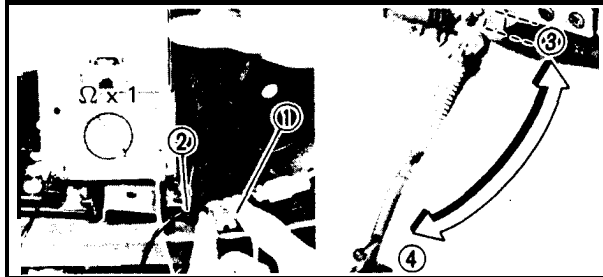



6. Neutral switch conduct check

- Disconnect the neutral switch lead (Sky blue ①) from the wire harness.
- *Connect the positive lead of the Pocket Tester (YU-33260) to the neutral switch lead.
- *Ground the negative lead of the Pocket Tester to the engine.
- Shift the gear, and check the neutral switch for continuity.

Transmission Position	Good Condition			Bad Condition		
	○	○	○	X	X	X
In neutral	○	○	○	X	X	X
In gear	X	○	○	X	X	○

○ : Continuity X : Discontinuity

BAD CONDITION



Neutral switch is faulty.
Replace it.

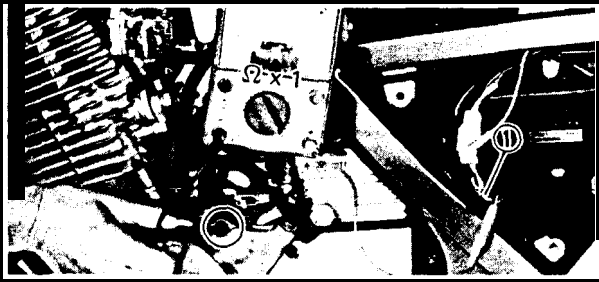

GOOD CONDITION

7. Ignition coil resistance test

- Disconnect the ignition coil lead (Orange ①) and spark plug lead ② .
- *Connect the Pocket Tester (Y U-33260) as shown.
- *Measure the primary and secondary coil resistances.



Primary Coil Resistance **A** :
0.48 ~ 0.72Ω at 20°C (68° F)
Secondary Coil Resistance **B** :
5.2 ~ 7.8 kΩ at 20°C (68° F)

OUT OF SPECIFICATION



Ignition coil is faulty.
Replace it.

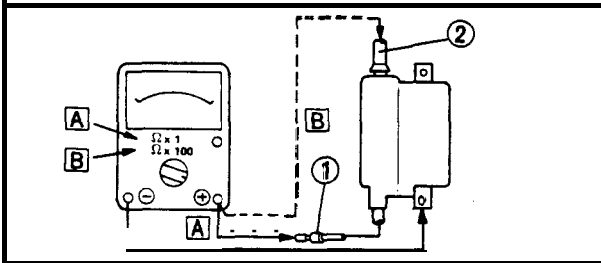

**BOTH RESISTANCES
* MEET SPECIFICATIONS**

6



8. Source coil resistance test

- Disconnect the CDI magneto leads (Brown ① and Red ②) from the wire harness.

*Connect the Pocket Tester (YU-33260) to the CDI magneto leads.

- Measure the source coil resistance.

 Source Coil Resistance (Brown ① – Red ②):
84 ~ 156Ω at 20°C (68°F)

OUT OF SPECIFICATION

Source coil is faulty.
Replace stator assembly.

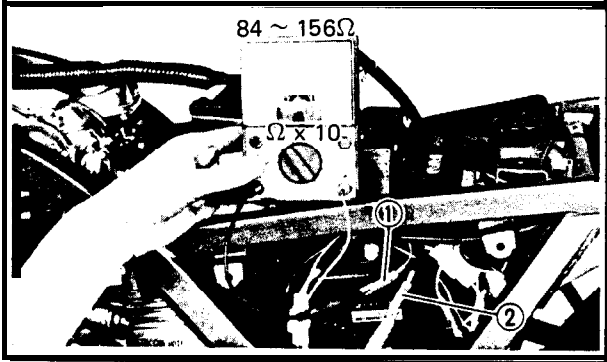

9. Pickup coil resistance test

- Disconnect the pickup coil leads (White/Green ①, White/Red ② and Green ③) from the CDI unit.

*Connect the Pocket Tester (YU-33260) to the pickup coil leads.

- Measure the pickup coil resistance.

 Pickup Coil Resistance (White/Green ① – Green ③, White/Red ② – Green ③):
92 ~ 138Ω at 20°C (68°F)

OUT OF SPECIFICATION

Pickup coil is faulty.
Replace stator assembly.

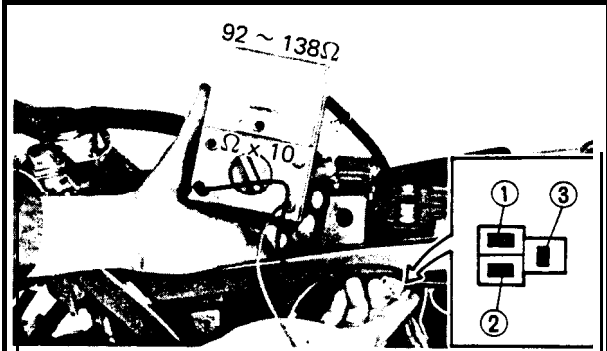



10. Check entire ignition system for connections.
• Refer to "WI RING DIAGRAM" section.

POOR CONNECTION



Correct.



OK

CDI unit is faulty. Replace it.

IGNITION CONTROL CIRCUIT OPERATION

The ignition control circuit on this model consists of the CDI unit, neutral switch and sidestand switch. If the engine stop switch and main switch are both on, the ignition spark can produce only if:

*The transmission is in neutral (The neutral switch is on).

OR

*The sidestand is up (The sidestand switch is on).

When one of both of the above conditions have been met, and the engine can be started by kicking the kick starter.



WHEN THE TRANSMISSION IS IN NEUTRAL



WHEN THE SIDESTAND IS UP

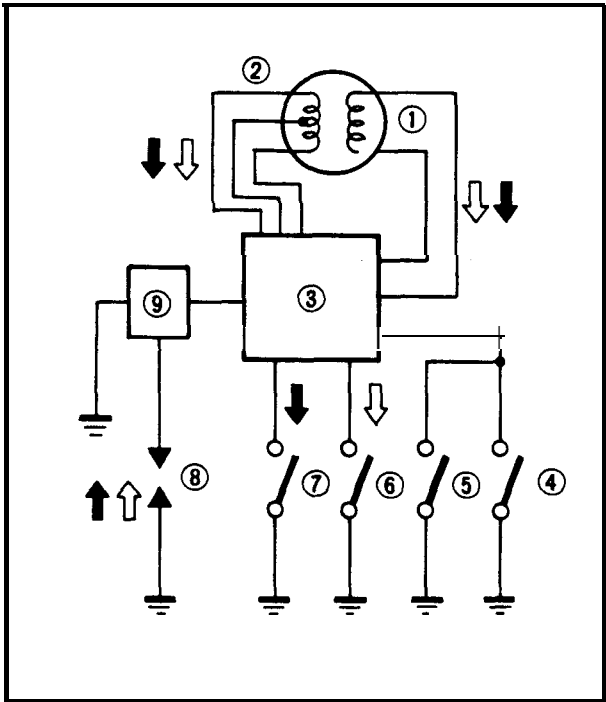

- ① Source coil
- ② Pickup coil
- ③ CDI unit
- ④ "ENGINE STOP" switch
- ⑤ Main switch
- ⑥ Neutral switch
- ⑦ Sidestand switch
- ⑧ Spark plug
- ⑨ Ignition coil

CHARGING SYSTEM

CIRCUIT DIAGRAM

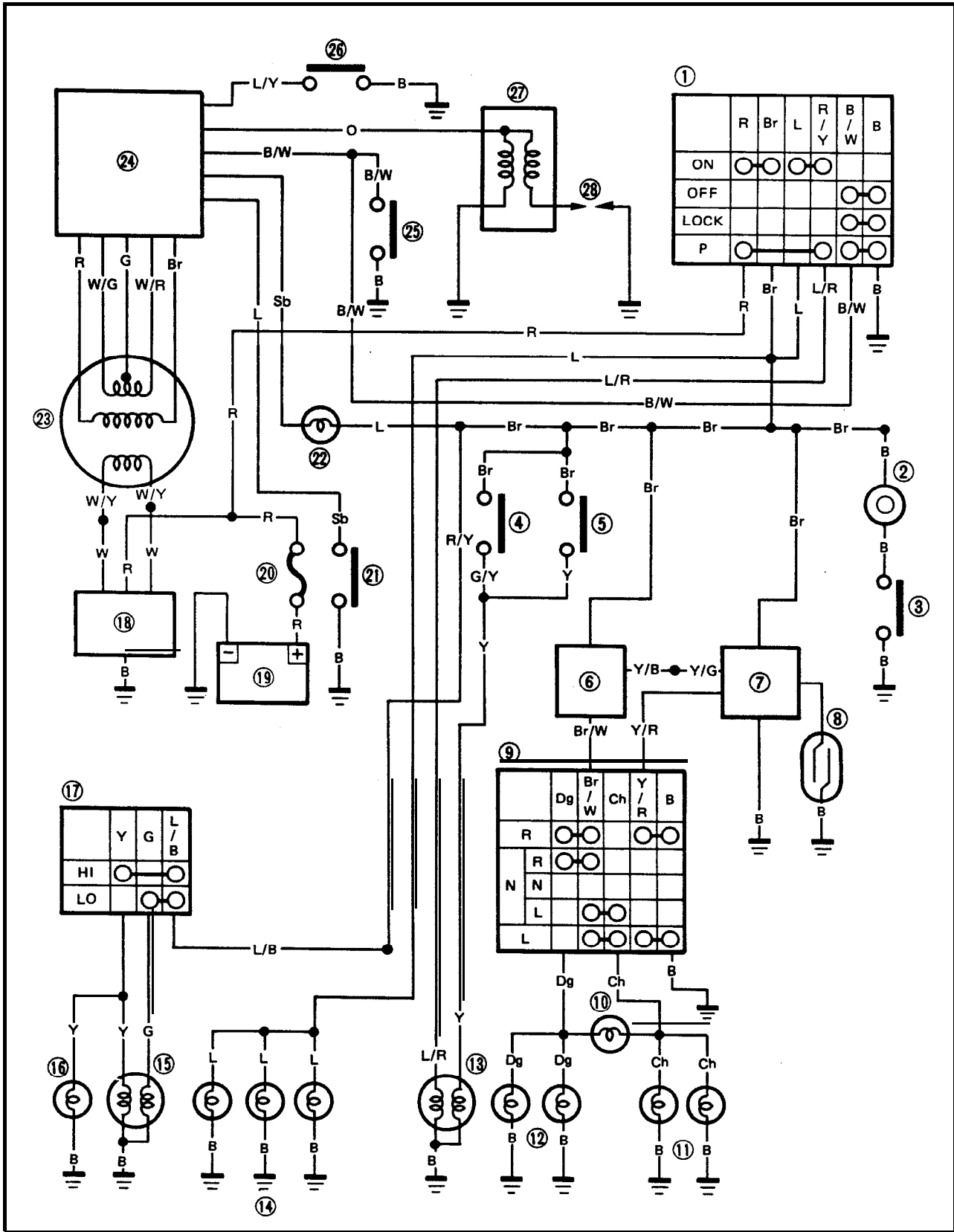

6

Aforementioned circuit diagram shows charging circuit in wiring diagram.

NOTE:

For the encircled numbers and color codes, see page 6-2.

- ① Main switch
- ⑱ Rectifier/Regulator
- ⑲ Battery
- @Circuit breaker
- ⑳ CD I magneto

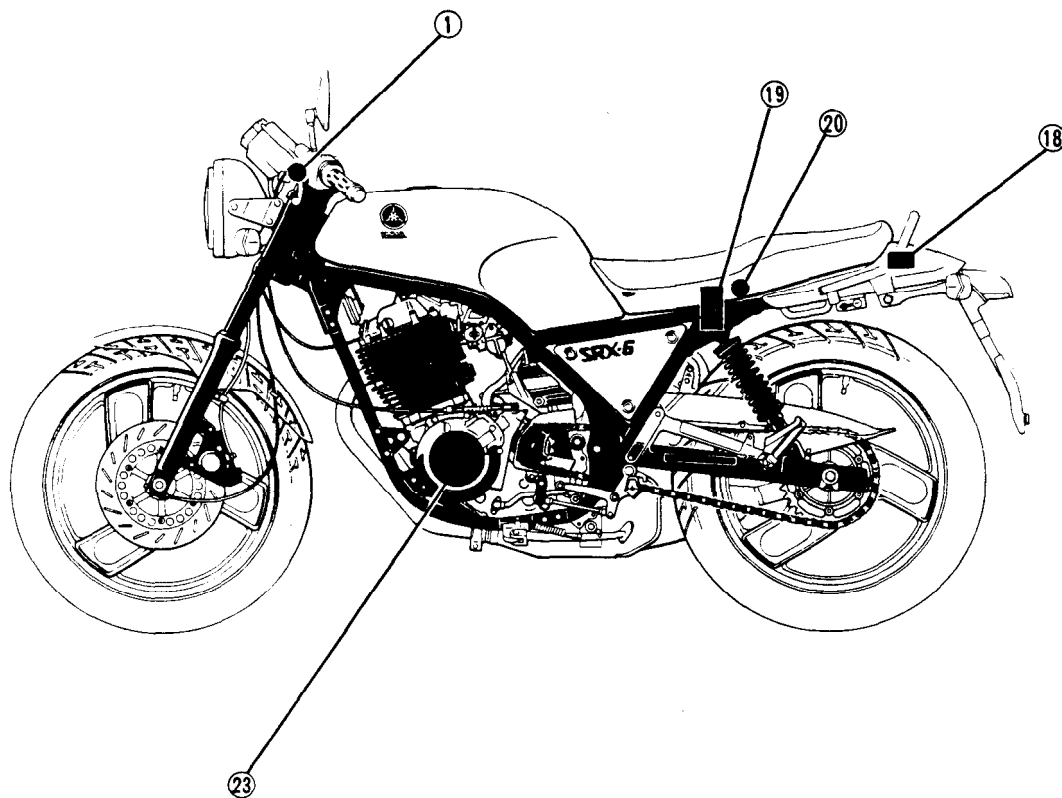

**TROUBLESHOOTING****NOTE:**

Before this troubleshooting, remove the side covers and seat.

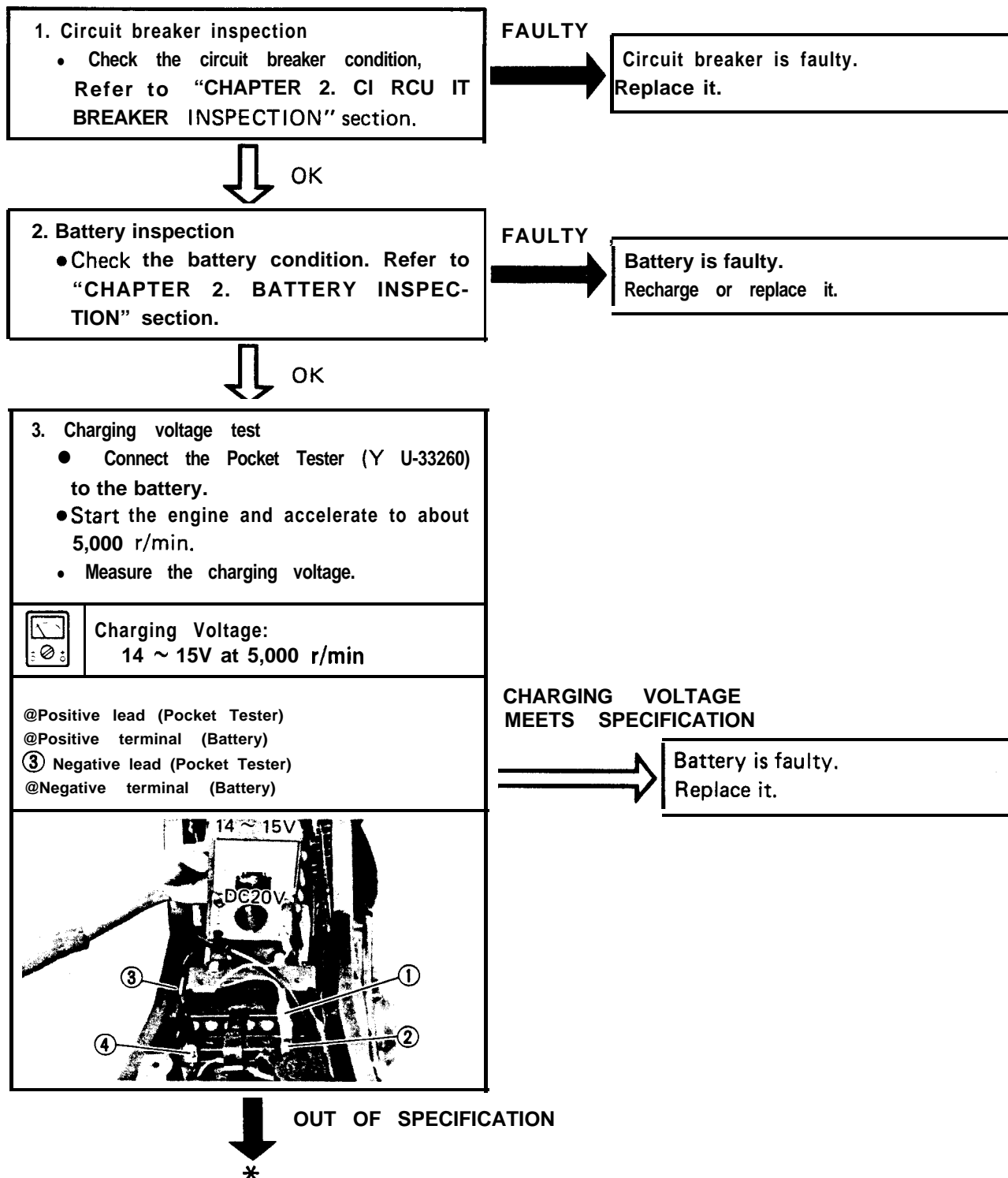
**6**



4. Charging coil resistance test

- Disconnect the CDI magneto leads (White/Yellow ① and White/Yellow ②) from the wire harness.
- Connect the Pocket Tester (YU-33260) to the CDI magneto leads.
- Measure the charging coil resistance.



Charging Coil Resistance
 (White/Yellow ① – White/Yellow ②):
 0.2 ~ 0.6Ω at 20°C (68° F)

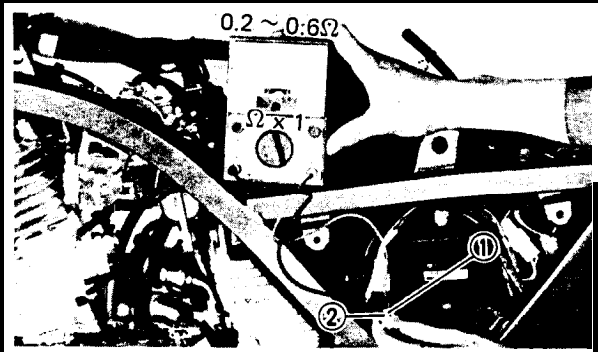

OUT OF SPECIFICATION



Charging coil is faulty.
 Replace stator assembly.



RESISTANCE MEETS SPECIFICATION

5. Check entire charging system for connections.
 @ Refer to “WI RING DIAGRAM” section.

POOR CONNECTION



Correct.



OK

Rectifier/Regulator is faulty. Replace it.



LIGHTING SYSTEM

CIRCUIT DIAGRAM

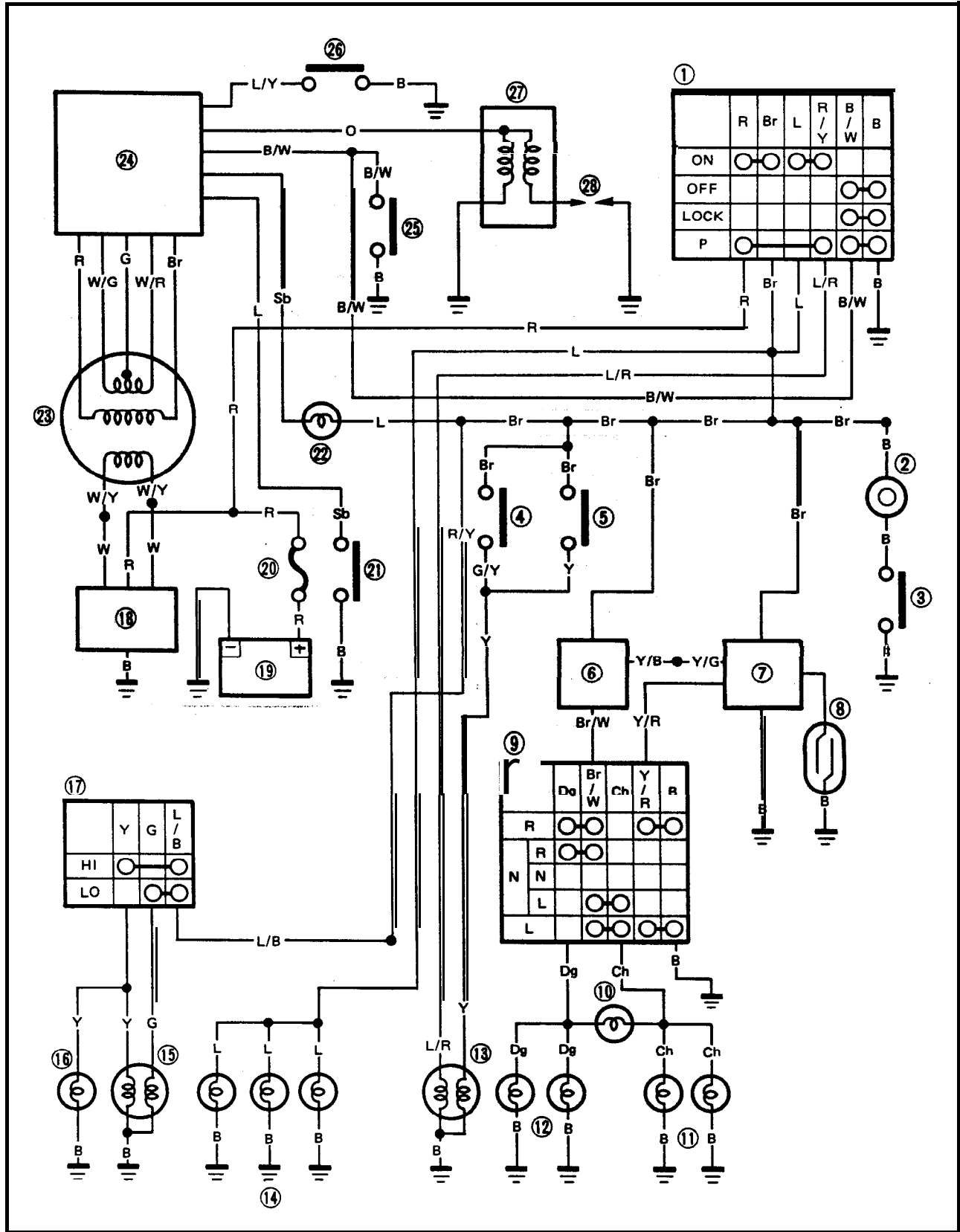

6



Aforementioned circuit diagram shows lighting circuit in wiring diagram.

NOTE:

For the encircled numbers and color codes, see page 6-2.

- @Main switch
- @Tail/Brake light
- ⑭ Meter light
- ⑮ Headlight
- ⑯ "HIGH BEAM" indicator light
- @"LIGHTS" (Dimmer) switch
- ⑲ Battery
- ⑳ Circuit breaker

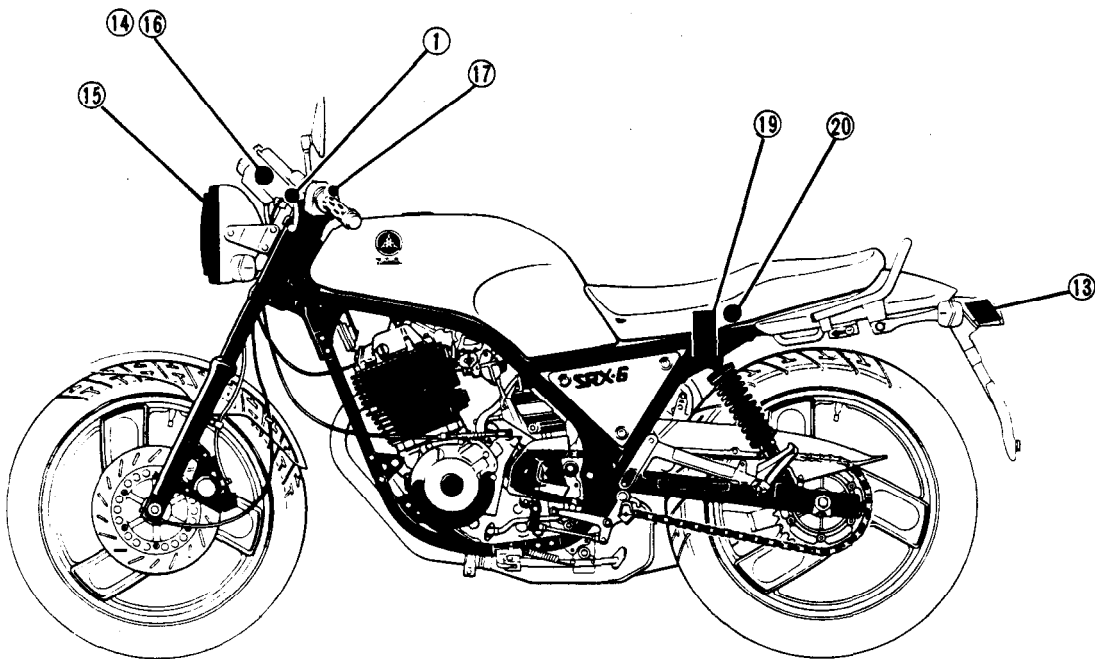



TROUBLESHOOTING

NOTE:

Before this troubleshooting, remove the side covers and seat.

HEADLIGHT DOES NOT COME ON. 1

1. Headlight bulb conduct check

- Remove the headlight bulb ①. Refer to "CHAPTER 2. HEADLIGHT BULB REPLACEMENT" section.
- Connect the Pocket Tester (Y U-33260) to the bulb terminals as shown, and check the bulb for continuity.

CONTINUITY DOES NOT EXIST ON CIRCUIT

Bulb is faulty. Replace it.

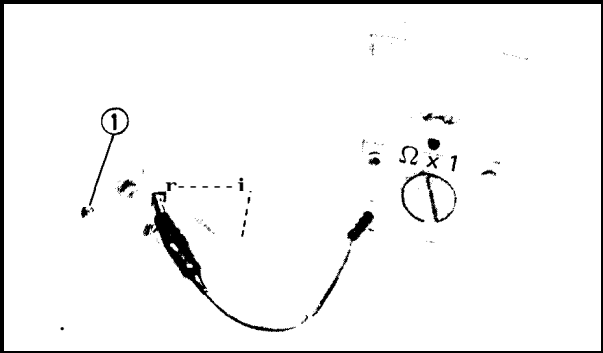

CONTINUITY EXISTS ON BOTH CIRCUIT

2. Headlight bulb socket conduct check

- Install the bulb to the headlight socket.
- Connect the Pocket Tester (YU-33260) to the headlight leads (Black ①, Yellow ② and Green ③), and check it for continuity.

CONTINUITY DOES NOT EXIST ON CIRCUIT

Bulb socket is faulty. Replace it.

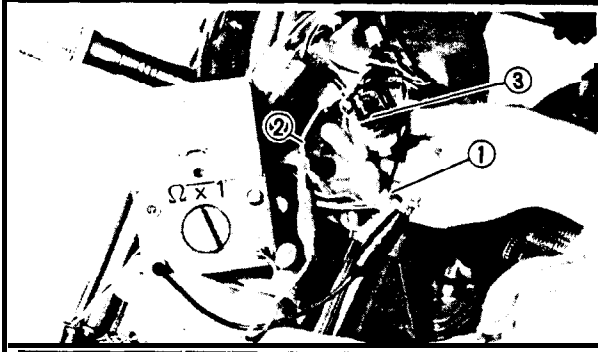

CONTINUITY EXISTS ON BOTH CIRCUIT

3. Circuit breaker inspection

- Check the circuit breaker condition. Refer to "CHAPTER 2. CIRCUIT BREAKER INSPECTION" section.

FAULTY

Circuit breaker is faulty. Replace it.

OK *



TAILLIGHT DOES NOT COME ON.

1. Taillight bulb conduct check

- Remove the taillight lens and bulb ① .
- Connect the Pocket Tester (YU-33260) to the bulb terminals as shown, and check the bulb for continuity.

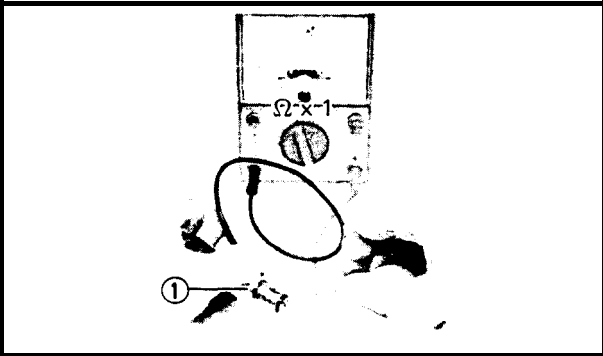

NO CONTINUITY

Bulb is faulty.
Replace it.

↓ CONTINUITY

2. Taillight bulb socket conduct check

- Install the bulb to taillight socket.
- Disconnect the taillight leads (Blue ① , Black ② and Yellow ③).
- Connect the Pocket Tester (YU-33260) to the taillight leads as shown, and check it for continuity.

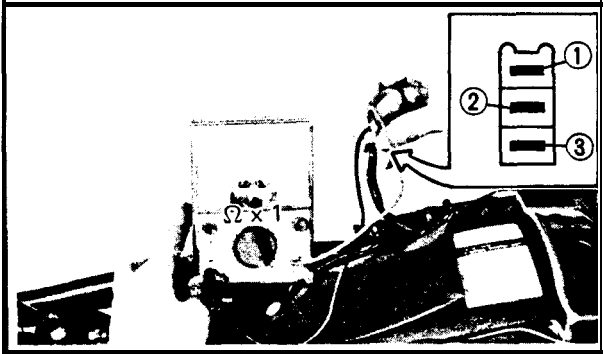

CONTINUITY DOES NOT EXIST ON CIRCUIT

Bulb socket is faulty.
Replace it.

↓ CONTINUITY EXISTS ON BOTH CIRCUIT

3. Circuit breaker inspection

- Check the circuit breaker condition. Refer to "CHAPTER 2. CIRCUIT BREAKER INSPECTION" section.

FAULTY

Circuit breaker is faulty.
Replace it.

↓ OK
*

6



4. Battery inspection
 *Check the battery condition. Refer to "CHAPTER 2. BATTERY INSPECTION" section.

FAULTY

Battery is faulty.
 Recharge or replace battery.



5. Lighting voltage test

- Connect the Pocket Tester (YU-33260) to the taillight leads (Blue ①, Black ② and Yellow ③).
- Start the engine and accelerate to about 5,000 r/min.
- Measure the lighting voltage.

LIGHTING VOLTAGE MEETS SPECIFICATION

Lighting system (Taillight) is good.



Lighting Voltage:
 14 ~ 15V at 5,000 r/min

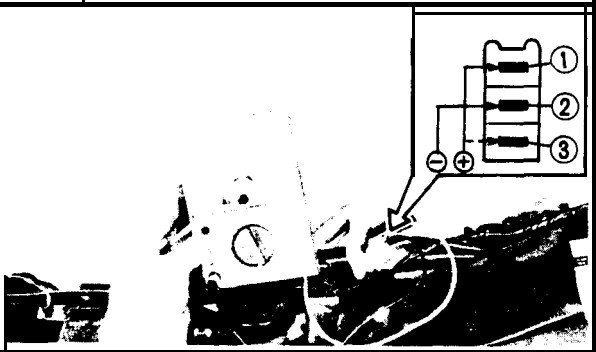



6. Main switch conduct check

- Check the main switch for continuity. Refer to "SIGNAL SYSTEM" section.

FAULTY

Main switch is faulty.
 Replace it.



7. Check entire lighting system for connections.
 * Refer to "WIRING DIAGRAM" section..

POOR CONNECTION

Correct.



Check the charging system.



SIGNAL SYSTEM

CIRCUIT DIAGRAM

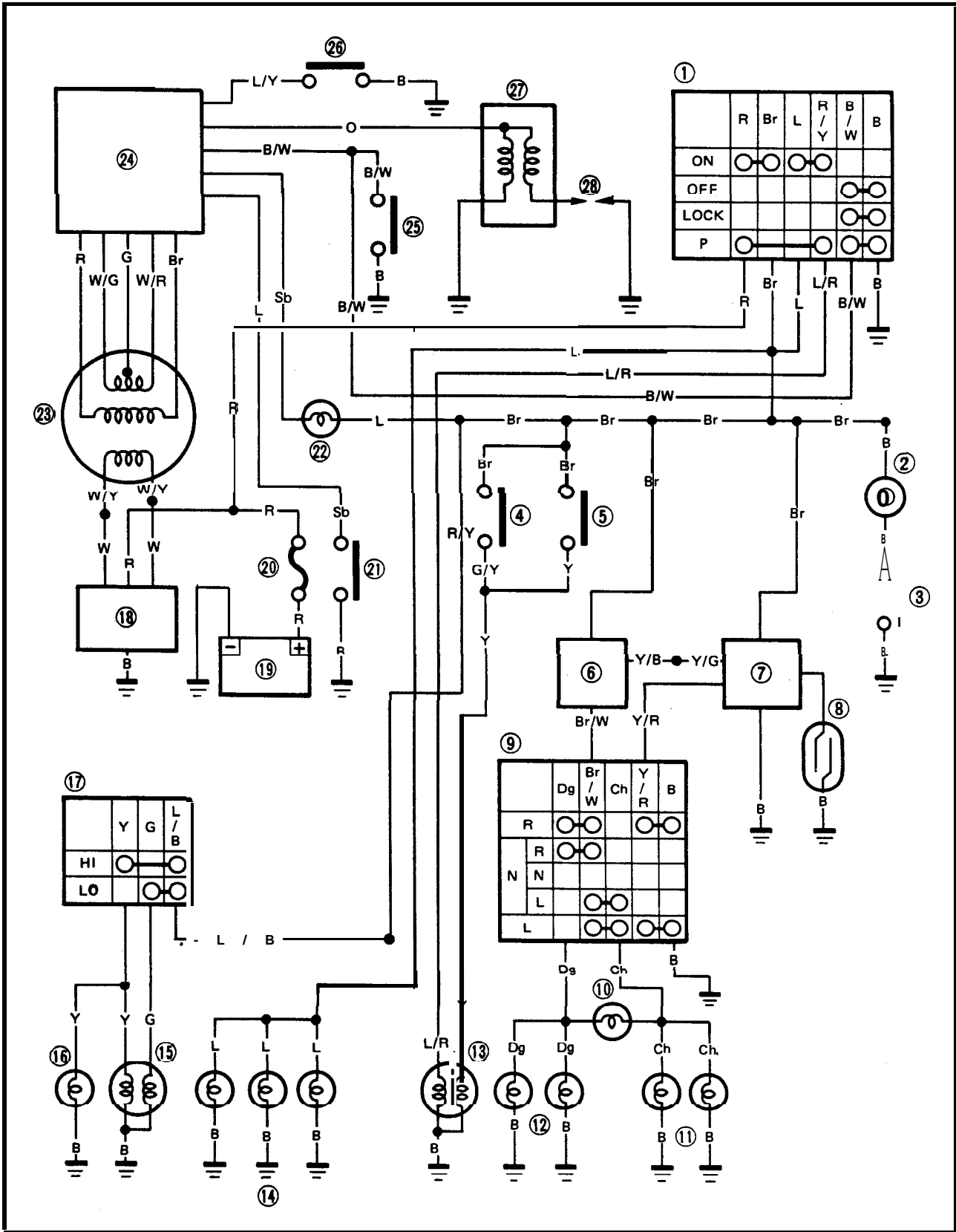



TROUBLESHOOTING

NOTE:

Before this troubleshooting, remove the side covers, seat and fuel tank.

THE FLASHER LIGHT AND INDICATOR LIGHT DO NOT COME ON.

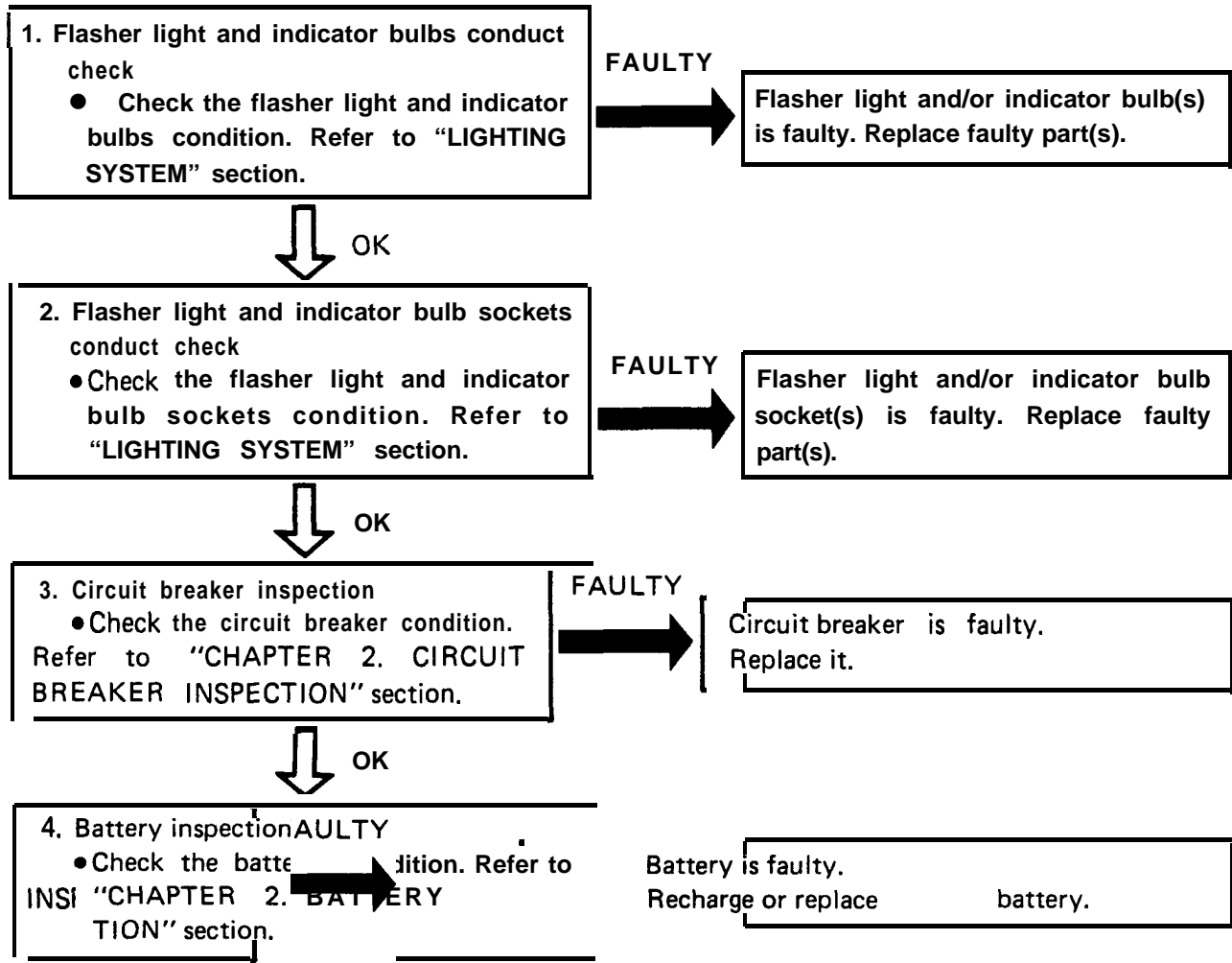

6

OK
a *



5. Battery voltage test

- Disconnect the flasher relay coupler.
- Connect the positive lead ① of the Pocket Tester (YU-33260) to the flasher relay lead (Brown ② - Wire harness side).
- Ground the negative lead ③ of the Pocket Tester to the frame.
- Turn the main switch to "ON", and measure the battery voltage.

LESS THAN 12V

Check main switch.

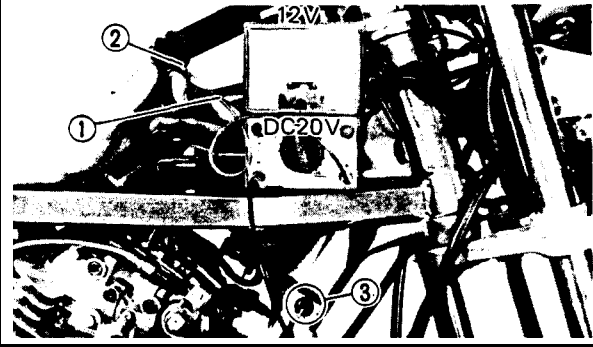

MORE THAN 12V

6. Flasher relay test

- Connect the flasher relay coupler terminals (Brown ① and Brown/White ②) with the jumper lead ③.
- Turn the main switch to "ON", and turn the "TURN" switch to "L" or "R".
- Check the flasher light condition.

DOES NOT LIGHT

Check "TURN" switch.

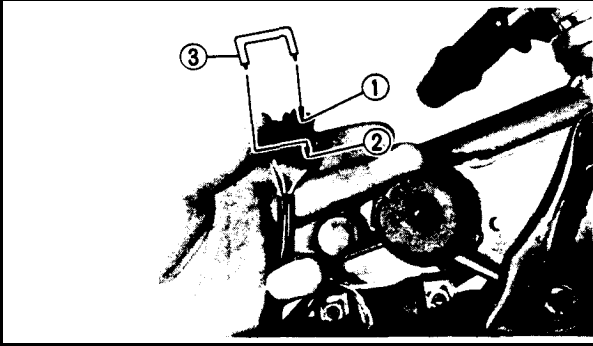

OK

7. Check entire signal system for connections.

- Refer to "WIRING DIAGRAM" section,

FAULTY

Correct.



LIGHTS

Replace flasher relay.

THE BRAKE LIGHT DOES NOT COME ON.

1. Brake light bulb conduct check
• Remove the taillight lens and bulb.
*Check the brake light bulb condition.
Refer to "LIGHTING SYSTEM" section.

FAULTY

Brake light bulb is faulty.
Replace it.

↓ OK

2. Brake light bulb socket conduct check
• Check the brake light bulb socket condition.
Refer to "LIGHTING SYSTEM" section.

FAULTY

Brake light bulb socket is faulty.
Replace it.

↓ OK

3. Circuit breaker inspection
• Check the circuit breaker condition.
Refer to "CHAPTER 2. CIRCUIT BREAKER INSPECTION" section.

FAULTY

Circuit breaker is faulty.
Replace it.

↓ OK

4. Battery inspection
• Check the battery condition. Refer to "CHAPTER 2. BATTERY INSPECTION" section.

FAULTY

Battery is faulty.
Recharge or replace battery.

↓ OK

5. Front and rear brake switches test
*Disconnect the front and rear brake switch couplers.
• Connect the front brake switch terminals (Brown ① and Green/Yellow ②) and rear brake switch terminals (Brown ③ and Yellow ④) with the jumper leads ⑤.
• Turn the main switch to "ON", and check the brake light condition.

DOES NOT LIGHT

Check the main switch.

FRONT

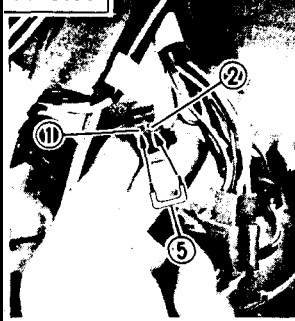

REAR

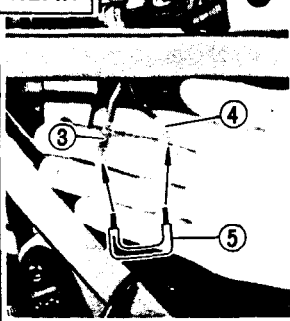

↓ LIGHTS
*

6



6. Check entire signal system for connections.

FAULTY



Correct.



OK

Replace front and/or rear brake switch(es).



THE "NEUTRAL" INDICATOR LIGHT DOES NOT COME ON.

1. "NEUTRAL" indicator light bulb conduct check
● Check the "NEUTRAL" indicator light bulb condition. Refer to "LIGHTING SYSTEM" section.

FAULTY

"NEUTRAL" indicator light bulb is faulty. Replace it.

OK

2. "NEUTRAL" indicator light bulb socket conduct check
● Check the "NEUTRAL" indicator light bulb socket condition. Refer to "LIGHTING SYSTEM" section.

FAULTY

"NEUTRAL" indicator light bulb socket is faulty. Replace it.

OK

3. Circuit breaker inspection
● Check the circuit breaker condition. Refer to "CHAPTER 2. CIRCUIT BREAKER INSPECTION" section.

FAULTY

Circuit breaker is faulty. Replace it.

OK

4. Battery inspection
● Check the battery condition. Refer to "CHAPTER 2. BATTERY INSPECTION" section.

FAULTY

Battery is faulty. Recharge or replace battery.

OK
*



5. Battery voltage test

*Disconnect the neutral switch lead (Blue ① -Wire harness side).

● Connect the positive lead ② of the Pocket Tester (YU-33260) to the neutral switch lead.

*Ground the negative lead ③ of the Pocket Tester to the engine.

*Turn the main switch to "ON", and measure the battery voltage.

LESS THAN 12V

Check main switch.

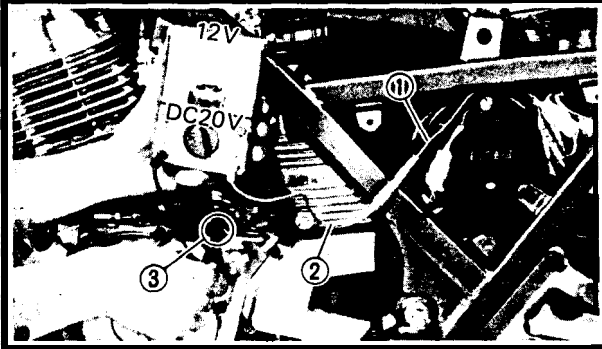

MORE THAN 12V

a

6. Neutral switch test

● Ground the neutral switch lead (Blue ① - Wire harness side) to the engine with the jumper lead ② ,

● Shift the gear in neutral.

● Turn the main switch to "ON", and check the "NEUTRAL" indicator light condition.

LIGHTS

Neutral switch is faulty. Replace it.

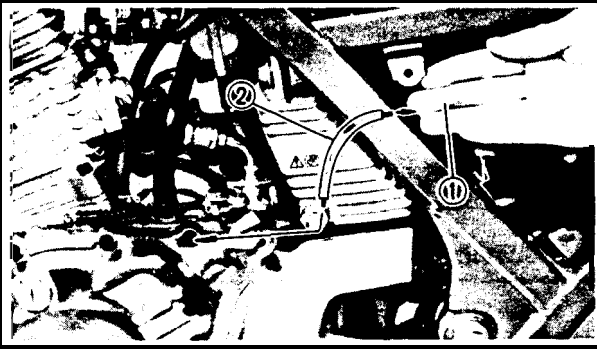

DOES NOT LIGHT



FAULTY

7. Check entire signal system for connection.

● Refer to "WIRING DIAGRAM" section.

Correct.

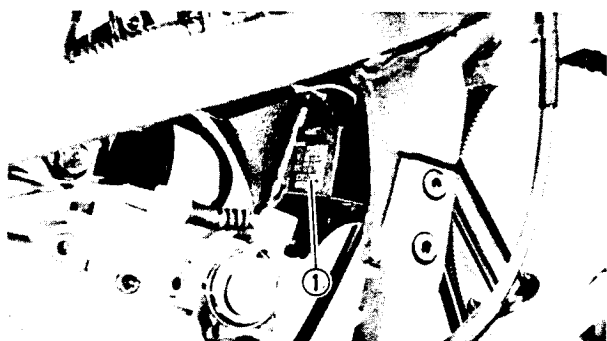

SELF-CANCELLING FLASHER SYSTEM
(Except for Germany)

Description

The self-cancelling flasher system turns off the turn signal after a period of time or distance involved in turning or changing lanes. Generally, the signal will cancel after either 10 seconds, or 150 meters (490 feet), whichever is greater. At very low speed, the function is determined by distance; at high speed, especially when changing speeds, the cancelling determination is a combination of both times and distance. The self-cancelling mechanism only operates when the motorcycle is moving; thus the signal will not self-cancel while you are stopped at an intersection.

@Flasher relay

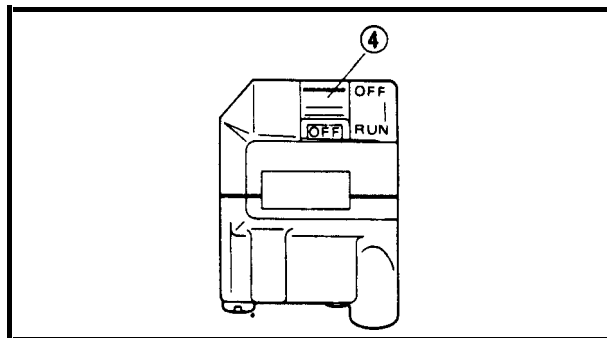
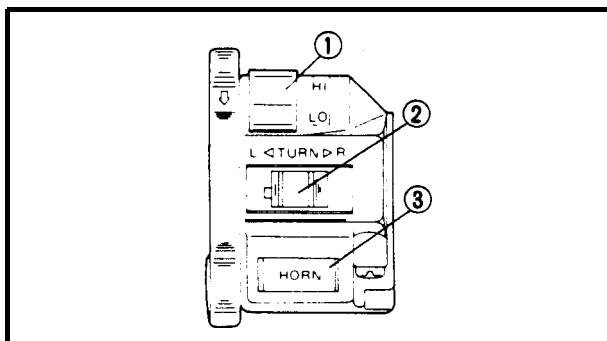

SWITCHES TEST

Switches may be checked for continuity with the Pocket Tester (YU-33260) on the "Ohm x 1" position.

6

- ① "LIGHTS" (Dimmer) switch
- ② "TURN" switch
- ③ "HORN" switch
- ④ "ENGINE STOP" switch

Main Switch

Switch Position	Lead Color					
	R	Br	L	R/Y	B/W	B
ON	○—○		○—○			
OFF					○—○	
LOCK					○—○	
P	○—○			○—○	○—○	

“LIGHTS” (Dimmer) Switch

Switch Position	Lead Color		
	Y	G	LIB
HI	0 ——— 0		
LO		0 ——— 0	

“TURN” Switch

Switch Position	Lead Color				
	Dg	Br/W	Ch	Y/R	B
R	○ ——— ○			○ ——— ○	
N	R	○ ——— ○			
	N				
	L		○ ——— 0		
L		○ ——— ○		○ ——— ○	

“HORN” Switch

Switch Position	Lead Color	
	P	B
OFF		
ON	0 ——— ○	

“ENGINE STOP” Switch

Switch Position	Lead Color	
	B	B/W
OFF	○ ——— ○	
RUN		